



WOODWAY  
PICTURES

# EVA GARNER™

THE SECRET OF EDEN



[WWW.EVA-GARNER.COM](http://WWW.EVA-GARNER.COM)

France - VF - 90min - 35mm

2023



## SYNOPSIS

In 2048, Captain Eva Garner is on a mission to lead the spaceship Eden to the limits of our solar system and drop off an intergalactic surveillance satellite. Alone and faced with the inflexibility of the machines around her, she realizes that they are hiding a terrible secret...

## DETAILED SYNOPSIS

My name is Eva Garner. In 2048, I embarked as commander of the spaceship Eden. The space agency assigned me to drop a satellite at the limit of our solar system, close to the Kuiper Belt. More than four years of artificial sleep was planned to make the trip to the drop point and just as much for the return to Earth.

Jack, an H22 humanoid, was in charge of the ship's maintenance while all data had been entrusted to Aurora, an Orion supercomputer of the last generation.

This mission seemed uneventful until the unusual behavior of the supercomputer made me discover the truth. My mission wasn't the one I thought I was entrusted with.

It actually consisted of moving away from the Earth for more than nine years.

In fact, a few years before my departure, the first symptoms of a terrifying epidemic had appeared, leaving no hope and not much time for humanity.

This uncontrollable disease would definitely invade the entire globe. Confronted by this situation, the Nations Council saw only one possible way out : Preserve as many human cells as possible for a future rebirth.

The spaceship Eden was immediately put under construction, and a shuttle put inside the hold. This new kind of engine would be used to store an incubator where two billion cells would be safely kept.

And as everything had to be started over from scratch, the Earth Nations decided that only a woman could take charge of such a responsibility.

Scientists were sure that the contagion would itself disappear after nine years, and the shuttle could return to Earth.

All these decisions had been made without anyone telling me a word. Everybody kept the secret, to protect me and to spare me from despair. It wasn't easy after I found out, but the machines knew, in their own way, how to give me back the taste for life. They encouraged me to find the willpower to overcome all this. I understood that I had to look to the future and accept the mission I hadn't expected...

After reaching Earth's atmosphere, the shuttle landed on 17th April 2052 on the landing strip of Monalooa Island. For many years, everything had been prepared for our return.



Soothed by the sun and the clear water of the lagoon, I quickly forgot I was just a poor castaway.

After reaching Earth's atmosphere, the shuttle landed on 17th April 2052 on the landing strip of Monaloa Island. For many years, everything had been prepared for our return.

And while Jack and Aurora organized our new life, Jules was born one morning. He was the first of the new generation.

Three years of peace and carelessness passed before suddenly, Aurora announced the approach of a tropical storm whose winds and waves would spare nothing...

We had to go quickly to the submerged zone of the base and definitively close the heavy doors behind us.

This underwater part had been built by the Oceanic Technological Research organization, in order to exploit the resources of the ocean. The vast construction consisted of many long tunnels leading to hundreds of rooms, some of which had been transformed to accommodate the incubator and gestation chambers where the first two hundred babies would soon be born.

Everything has been perfectly prepared and nothing that would make our lives easier was missing. Vast sheds contained stocks overflowing with canned goods, clothes, machines and tools of all kinds. So it was there, at the bottom of the ocean, that the births took place. The first two hundred babies came little by little, starting on the same day that Jules turned 5.





INTERVIEW WITH  
**Alexandra RIDER,**  
Director, screenwriter



**The total humanity extinction is an unsettling situation...**

**Alexandra Rider :** Absolutely! The effects that such a cataclysm would have are a mystery for now... Are we destined to disappear like the dinosaurs?

Questions like that without real answers led me to imagine an epic where the heroine is confronted with the sudden extinction of humanity. The great inner strength she has to repair such irreparable damage will make her a legend for the next generations.

**The machines have an important role during this mission.**

**AR :** Yes, I organized the story around a specific period of time and made the choice of a programmed rebirth. Under the control of the Nations Council, scientists have developed a futuristic program planned by the intelligence of machines. They expect that Orion, the last of the supercomputers, will be the spearhead of this revival. He will communicate his knowledge to the children of the first new generation. He will teach them the basics of a new life and the need to stay in perfect harmony with the earth to reconquer the world.

### Why did you follow up on this story ?

AR : I wanted to develop the main characters over a period of thirty years. Such a long time seemed difficult in one film, so I had to imagine five parts interlocking into each other. That way, during each episode, the viewer can follow the heroes on a close level while finding the answers to their questions from the previous one.

### You said it's a new concept, why ?

AR : First, our story stands out from the traditional heroes who are invincible with super powers... I believe that violence must stop, that it is a real disruptive element for young people. I want to show that cinema and video games are not intended to promote violence. Eva Garner's actions are not based on the extraterrestrial or military notions that are too often exploited in entertainment... I also wanted to move away from the bad taste of over-sexualization and avoid any religious or ethnic rapprochement. The humans cells were chosen because they were healthy, not for their origins.

### What are this epic's messages ?

AR : I wanted this story to lead to reflection and imagination and encourage youth to find real values... Eva Garner's story is all about will. The heroine's character is really determined, even though she is left alone with two machines, lost, not knowing if she will ever return to Earth. I would like the viewer to feel concerned and to imagine what they would do in such a situation. I often asked myself the question: would the story be different if there were several people aboard the ship Eden? What would have happened? The extraordinary situation would certainly have led the crew to first fight the machines, and finally each other. The conflicting spirit of man would have been their fatal flaw, leading the project to failure. This assumption encourages the Eden project's proponents to only consider the presence of a single human being. They are certain that humans will not give up, that it is their duty to survive. However, humanity's natural instincts have evolved and experience allows them to avoid repeating past mistakes. Their revival will be built on a new basis, through a systematic questioning of what has been done before.





### The images are also a new concept.

AR : For this project, I had the chance to work with the French studio Artheros. I had been looking for a new kind of character for a long time, and Artheros Studio gave me a heroine that I found awesome.

We directed the film towards realism. The graphics aren't cartoon-styled and all elements of the scenes are close to reality. I must say that we had a hard time imagining Jack. After some sketches, I really liked the idea of the black visor! That's why Jack has a special character. He doesn't have a face, but as time goes by, he has expressions and feelings.

### Doli, is she a small Jack ?

AR : Yes, it's a bit like that! Doli has an important part in the screenplay, and a friendly relationship with the main characters. I thought it was necessary to bring some laughs to the story. At first, we wanted to do a little thing with hair and big eyes, but in the end, we opted for this concept of a flying ball that gives her a very likable android aspect.

### Doli is always making negative motion that looks like she does disagrees. What does it mean ?

AR : Doli has to watch out for any oxygen leaks on board the ship. She is in permanent magnetic suspension and freely moves through the different rooms of Eden. In my opinion, her negative movements mean "There is no problem with the oxygen."



### And what about Orion the super computer?

AR : Orion was designed by Professor Helmott. He is an Orion 3 supercomputer, the most advanced of his generation. He later chooses the name "Aurora." During her adventures, Eva discovers that Aurora is actually essential to the proper functioning of the android Jack. Aurora feeds the terminal that provides Jack with energy. Until then, Eva thinks that Jack is autonomous, but she finally realizes that the two machines have a close relationship. In the evening, when Jack has to recharge, Aurora is able to explore his circuits.

### How can Orion be everywhere?

AR : Unlike the movie *2001: A Space Odyssey*, I wanted the Orion supercomputer to have no limits. In our case, there is not an eye in every room: Aurora is just everywhere. He generates a new wave system named Alphaflow. This wave is essential to his learning. Orion is like a child: he looks at the world, learns from it, and records documentation on what he learns. His constant acquisitions are stored in his central memory, and will allow him to transmit his knowledge to the children of the new generation...

### The staging is very much like today's cinema.

AR : Yes, I wanted the staging to be as close to reality as possible. The construction of the scenes is based on real-life traveling, focus, lighting effects, and special effects... The various flashbacks over several years reveal the heroine with different physical aspects. Eva's hairstyles and outfits, for example, have been extensively studied to keep as much realism as possible.



POSTERS



EVA GARNER  
THE SECRET OF EDEN

EVA GARNER  
THE SECRET OF EDEN

EVA GARNER  
THE SECRET OF EDEN

EVA GARNER  
THE SECRET OF EDEN

EVA GARNER  
THE SECRET OF EDEN

2048  
MY LEGEND IS BORN

2048  
MY LEGEND IS BORN

2048  
MY LEGEND IS BORN

## EVA GARNER'S ADVENTURES

### Eva Garner II - The First Generation

From then on, our little world began to grow and gradually invade the maze of rooms that had been placed at our disposal. It quickly became like a village, where everyone had their place, and to which I was happy to give the name of "Flower Village." The little girls and boys gave life to this austere place and their laughter soon echoed off the impassable walls of our underwater world.

I began to consider it a cocoon, a sort of ark lost at the bottom of the water, from which we'd emerge when the time came.

Aurora shared his immense knowledge and became a teacher for the children. Jack, for his part, took his role head on, and cared for

the little ones as well as the best nannies could have ever done! I was surprised by his patience while his experience kept growing over time. The piled-up reserves would inevitably run out one day so, without being asked,

Jack took care of the plankton machine, a strange apparatus that our predecessors left us to produce the necessary substance for food. He suddenly became passionate about chemistry, which he put to good use by reinventing flavors through molecular gastronomy, giving us exquisite dishes.

Flower Village existed in peace and happiness for twenty years. One day we discovered a hidden place, an area that was totally ignored.





It was a passage leading to an impressive boarding hall where an old submarine was docked. This submersible had been waiting there for more than thirty years, and its dark and wet mass all covered with algae couldn't hide the rust which coated its fuselage.

This strange discovery kept us busy for a little while. Was it put there to be used? If so, why did they leave it in such bad condition? A lot of questions kept Flower Village worried while only one of us had a certainty. Jules believed that this machine wasn't left there by chance. For him, there wasn't any doubt: that submarine was there so that we could use it.

It was time to leave our cocoon, especially since the next two hundred babies would considerably reduce our space and reserves.

Jack was once again very inventive. I don't know how, but he began to tame mechanics as he had done with baby bottles, the plankton machine, molecular cooking and all those things that accompanied our lives.

We named the submarine "Noah" in memory of the Ark. Then Aurora developed an interest in marine life. With his thirst for adventure, he set about training a brilliant crew to whom he taught underwater science, map reading and the study of sonar. That's how, despite my worries, Jules decided to go to sea.

He embarked with eighteen boys as a crew, without forgetting Jack, who he named his assistant.

### Eva Garner III - A New Shore:

Once underwater, the old submarine didn't show any serious damage and the well-instructed crew headed north, not far from the Tropic of Cancer, to a shoreline carefully chosen by Aurora.

Noah emerged from the water in the middle of a sunny cove, and the crew landed on a sandy beach where man had never set foot. Aurora, once again, surprised me. They were at the shores of Pocanoa, the biggest reserve on Earth, a kind of paradise which had been preserved in its wild state and protected from any human presence for half a century. It was an ideal place to start all over again...



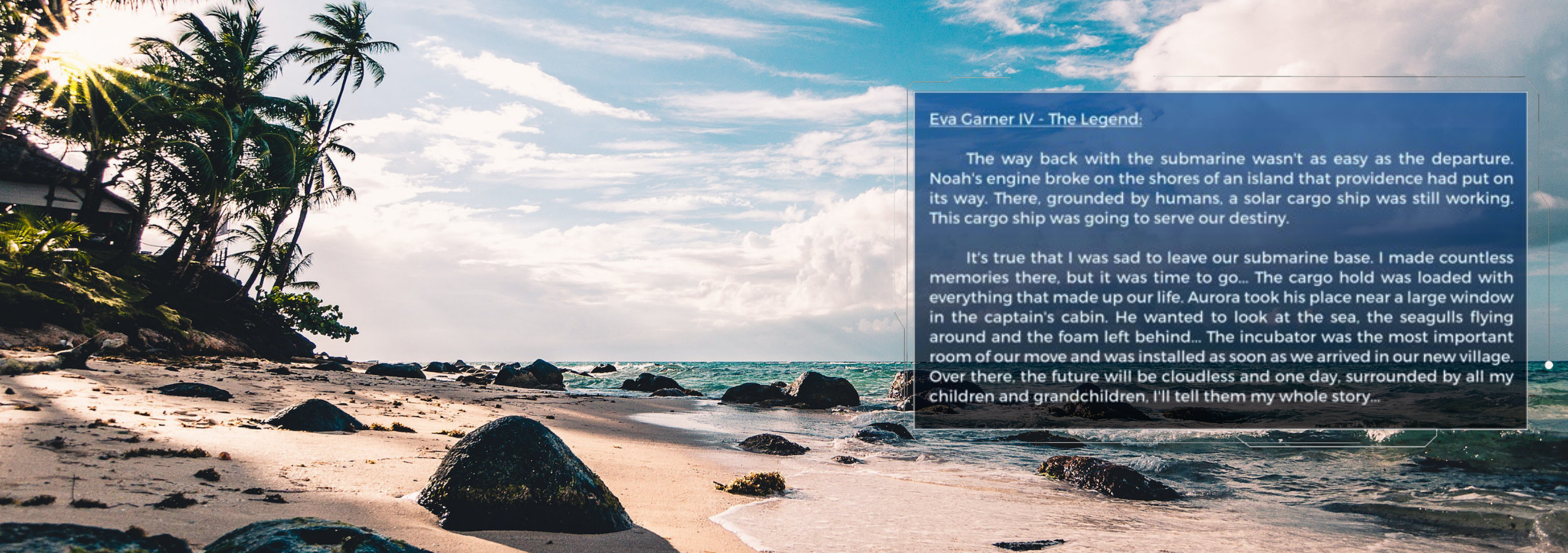

### Eva Garner IV - The Legend:

The way back with the submarine wasn't as easy as the departure. Noah's engine broke on the shores of an island that providence had put on its way. There, grounded by humans, a solar cargo ship was still working. This cargo ship was going to serve our destiny.

It's true that I was sad to leave our submarine base. I made countless memories there, but it was time to go... The cargo hold was loaded with everything that made up our life. Aurora took his place near a large window in the captain's cabin. He wanted to look at the sea, the seagulls flying around and the foam left behind... The incubator was the most important room of our move and was installed as soon as we arrived in our new village. Over there, the future will be cloudless and one day, surrounded by all my children and grandchildren, I'll tell them my whole story...



## Artheros Studio

*Led by young artists bringing new ideas ...*

Based in Paris, Artheros Studio is diversified in characters, animations and visual effects and runs on its own original engine concept, built with Python.

The "Overreal" System works frame by frame and allows a realistic render with high-quality textures, real facial expressions, soft character animations, fluid cameras movements and cinematic focus. The final result is a beautiful 35mm classic motion picture.

SKETCH

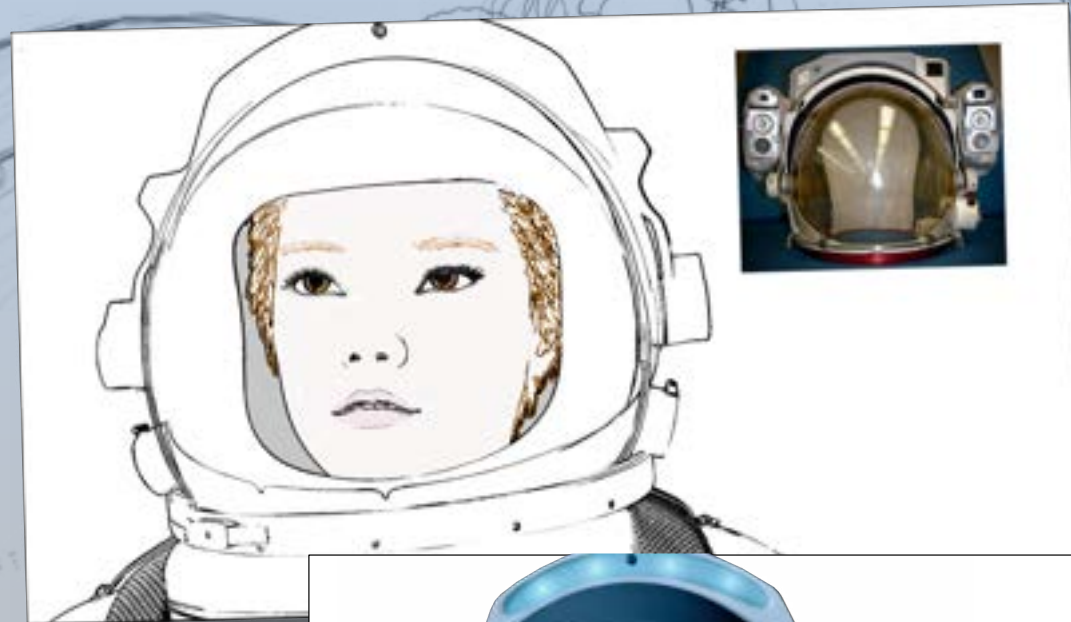
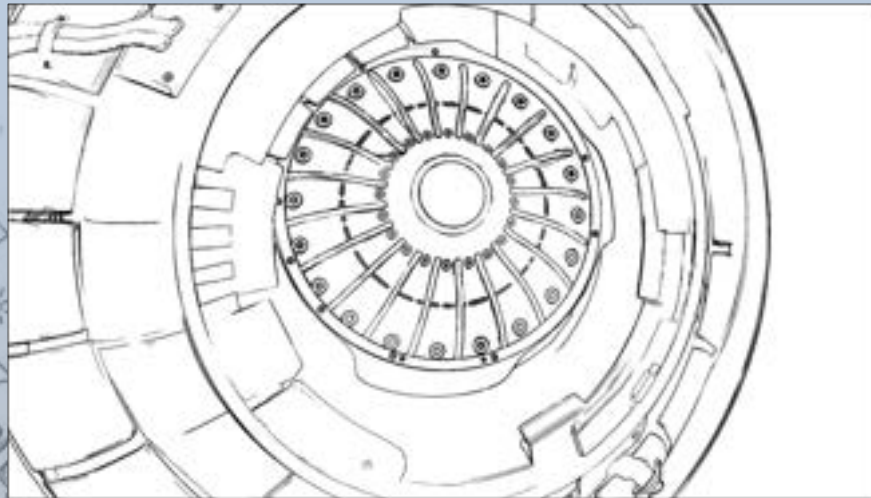

SKETCH

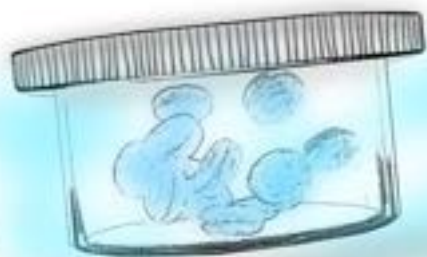
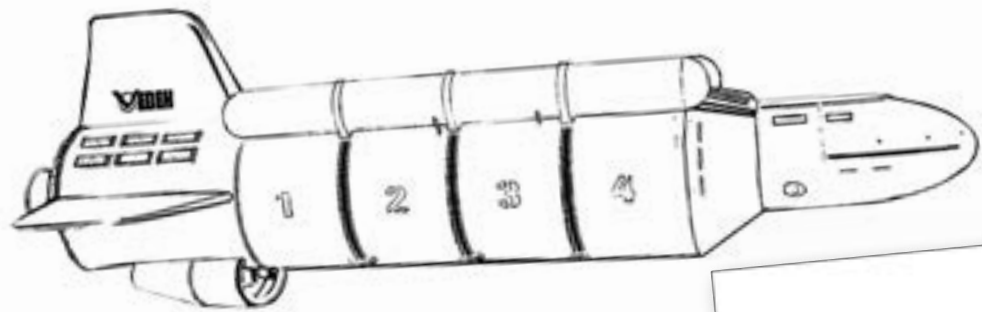



Jack H22

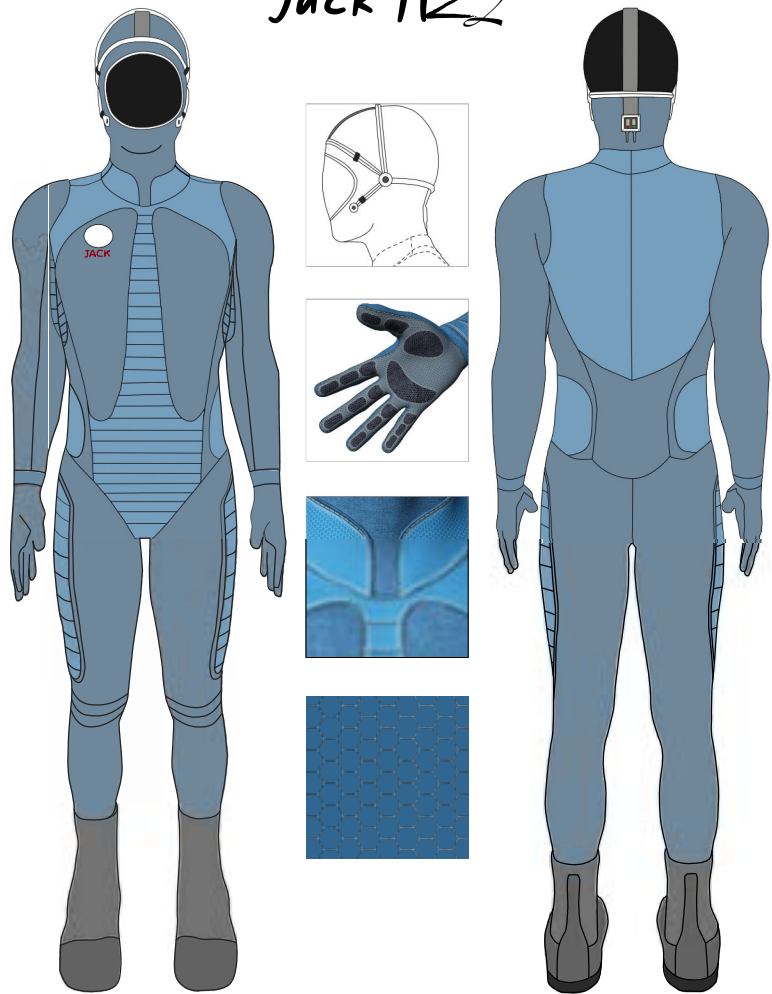

Orion III

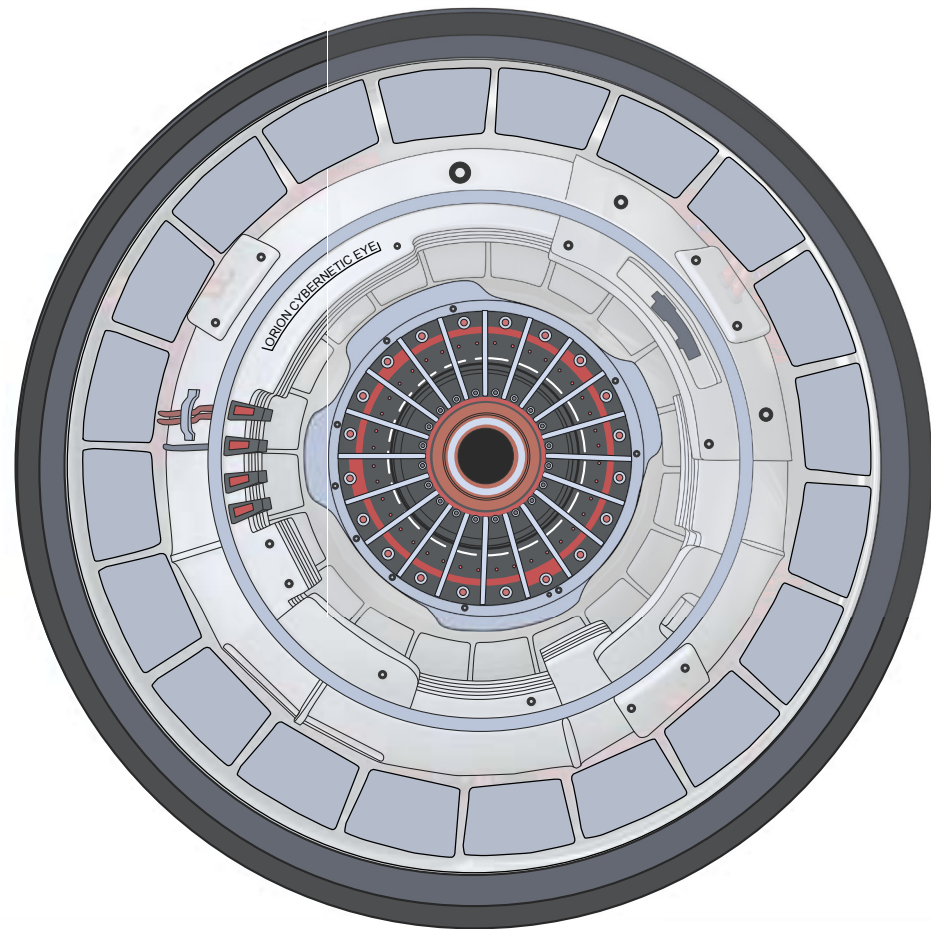

Spaceship Eden

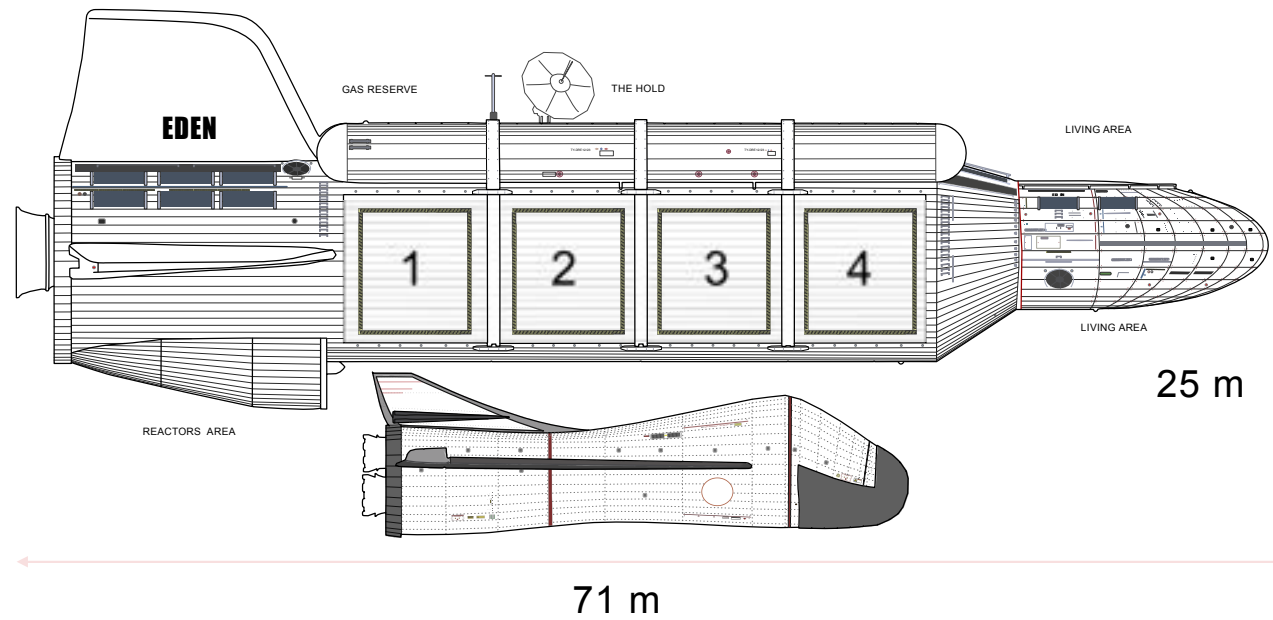

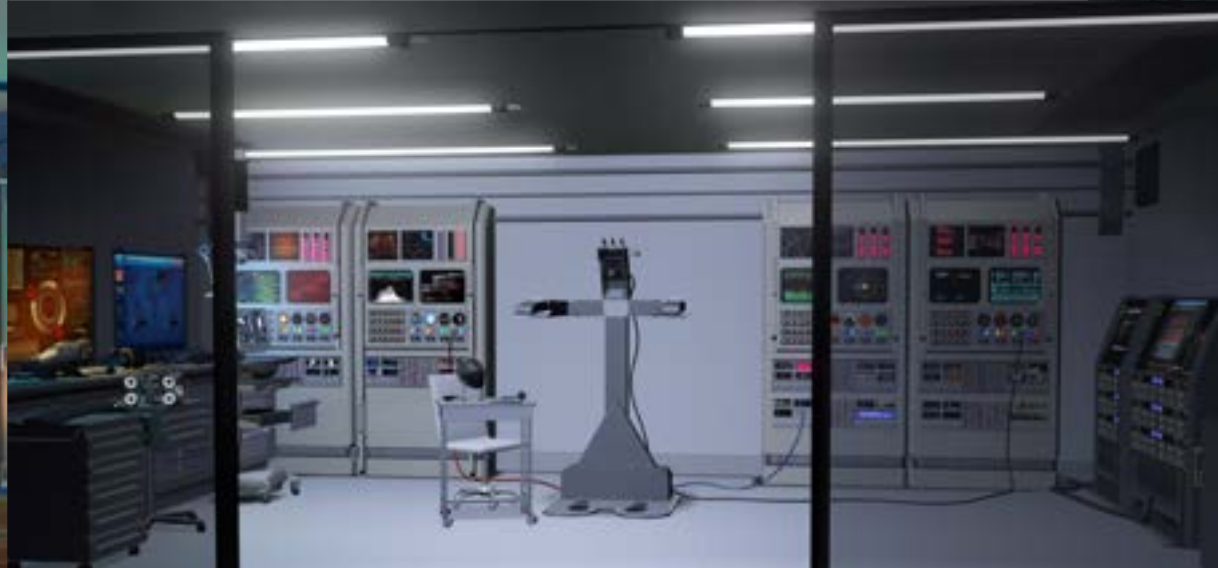

GRAPHIC ELEMENTS





EVA GARNER



ORION



JACK



DR. HELMOTT



NEIL SAMPTOWN



DR. MARVIN



JANE



DOLI



JULES



PAUL NOLAN



MARC SPENSER



SOPHIA LLOYD



JOHN DILANGO



JACKIE JOHNSON

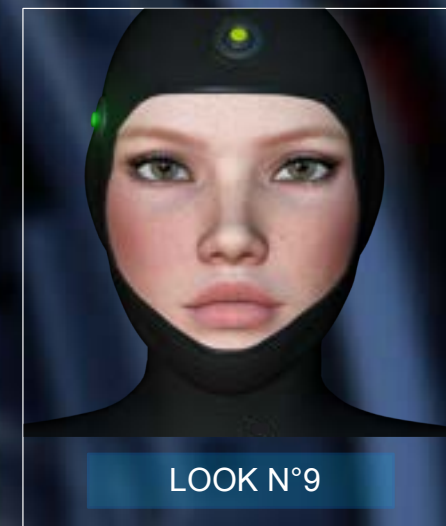
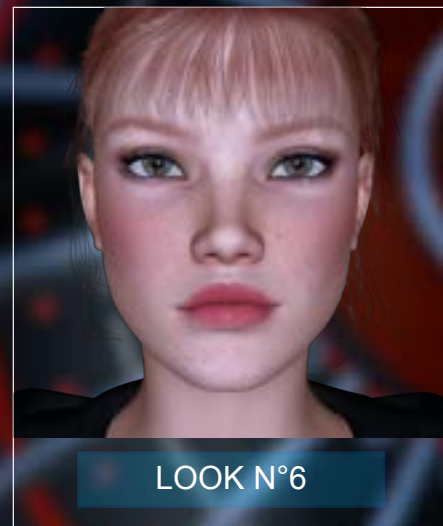
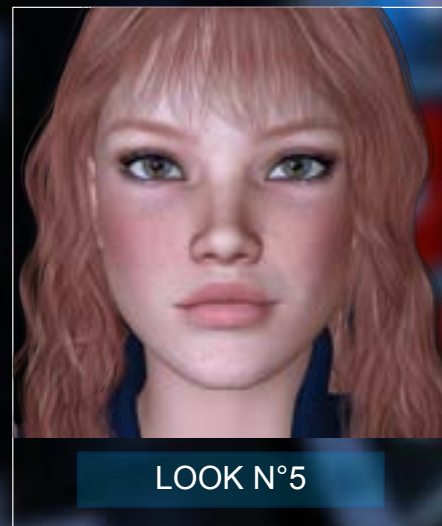
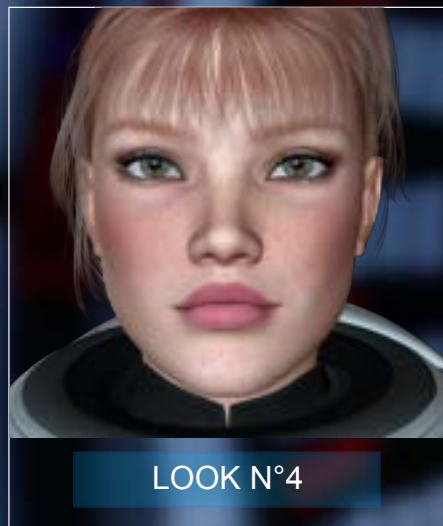
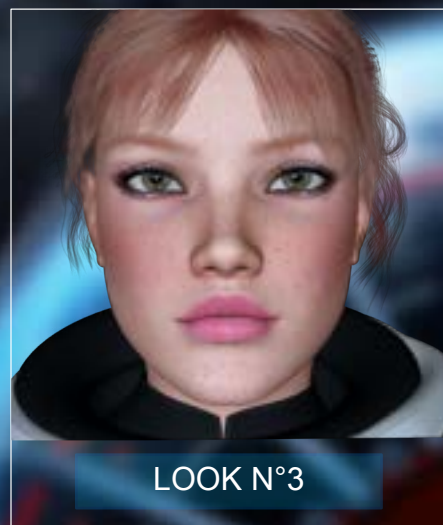
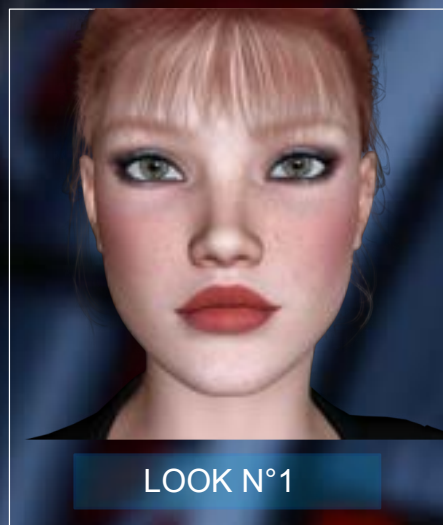

# EVA GARNER THE SECRET OF EDEN

1



## EVA GARNER COMICS

Alexandra Rider and Artheros Studio worked together to create the comics.





ORIGINAL MUSIC  
by MOONCHALEX

## Technical List

Scenario & Directed by  
Alexandra Rider

Director of Photography  
Béatrice Simon

Original idea of  
Cebarre

CG Supervisor  
Jessika Harban

Produced by  
Rider Enterprises

3D Development  
Gérard Hubert

Original Music  
MoonChalex

Technical Director  
Bernard Petit

Artistic Direction  
Hélène Giraud







WOODWAY  
PICTURES



© The brand Eva Garner as well as the characters are registered in  
France and other countries. All rights reserved.